

Admitted: \_\_\_\_\_

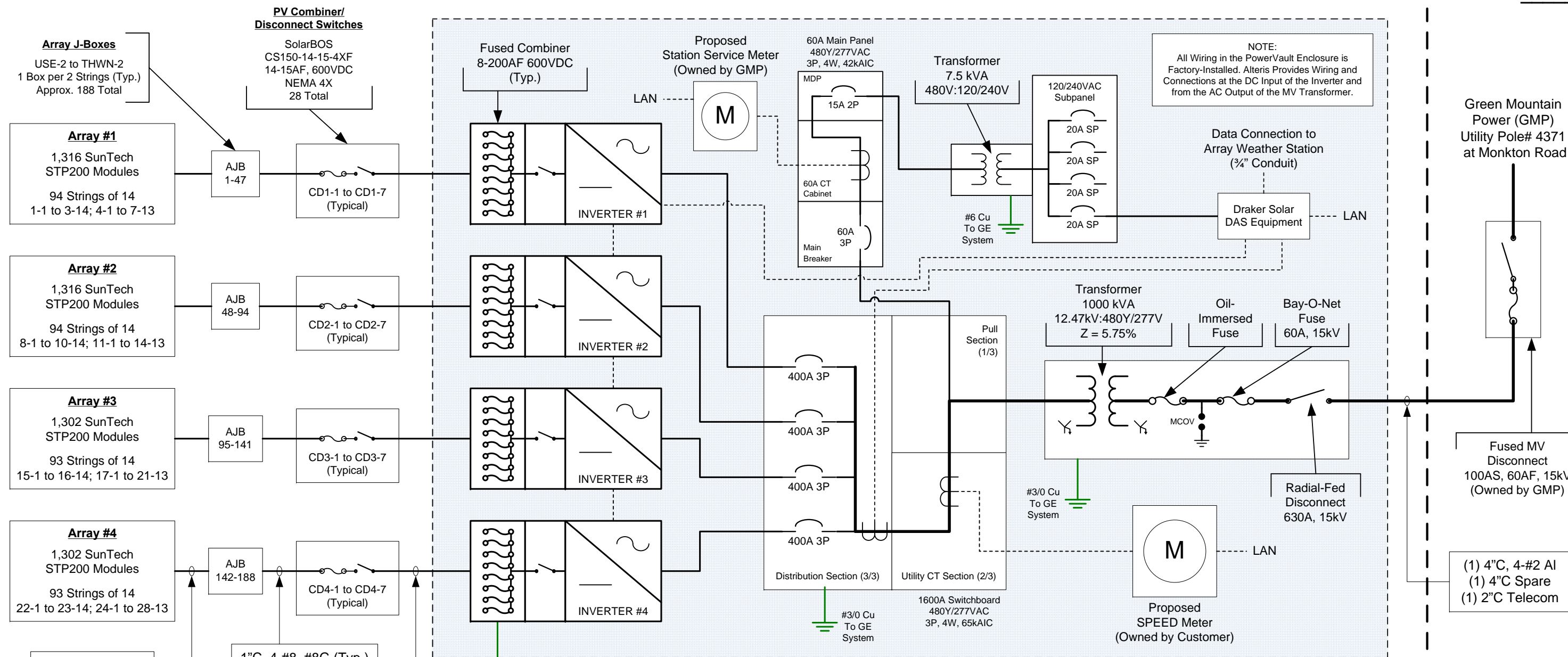

**PV Powered PowerVault MV-1040kW**  
 (4) PVP260kW Inverters, 301A ea., 480VAC  
 Power Factor >0.99, THD <3%  
 Internal DC GFPD  
 Integral Fused DC Subcombiner  
 UL 1741/IEEE 1547 Listed

Equipment Supplied and Installed by Solar Contractor

Primary Service and Protective Equipment (Owned by GMP)

Solar PV System Summary
1,047.2 kW DC STC
5,236 SunTech STP200-18/Ub-1 Modules
374 Strings of 14
Array Tilt = 30°, Azimuth = 180° True
<small>This document is the property of Alteris Renewables. It is intended for the sole use of the Customer and Project indicated in the title block. It may not be used, reproduced, disseminated or transferred in any manner, without written permission of Alteris Renewables.</small>

**NOT FOR CONSTRUCTION**

DRAWING	One-Line Electrical	ORIGINAL DRAWN BY	LWS
CUSTOMER	Ferrisburgh Solar Farm	ORIGINAL DATE	1-4-10
	Addison Solar Farm, LLC Route 7 – Monkton Rd Ferrisburgh, VT 05456	REVISED BY	AJS
SCALE	NONE	REVISION DATE	1-26-10
	REV. NO. 2		

**alteris™**  
 RENEWABLES

**ALTERIS RENEWABLES, INC.**  
 64 Main St., Montpelier, VT 05602  
 Phone: 802-223-7804 | Fax: 802-223-8980