

OEM Equipment

Electrical Apparatus

800-64

Four-Position Sectionalizing Loadbreak Switches

GENERAL

The Cooper Power Systems four-position sectionalizing loadbreak switch is designed for use in transformer (mineral) oil, R-Temp® or Envirotemp® FR3™ fluid filled pad-mounted transformers or distribution switchgear. The switches meet the full requirements of the latest revision of both IEEE® and IEC standards.

Sectionalizing switches can be used on single- and three-phase grounded wye or delta systems. They are used in underground residential applications with loop feed, and in three-phase commercial industrial installations where the ability to use an alternative source of power is necessary. They can also be used to switch on and off a primary cable tap on a transformer.

The under-oil switch can be installed near the transformer core/coil assembly, thus minimizing cable capacitance. With cable capacitance minimized and all three phases switched simultaneously, the likelihood of ferroresonance is greatly reduced. All switches are hotstick operable and available in several different blade configurations (Refer to Table 5).

Cooper Power Systems sectionalizing switches rotate 360° in either direction for alternate source selection. An externally installed limiting plate prevents rotation to positions other than the one desired. A spring-loaded activating mechanism ensures quick loadbreak action and positive contact engagement through all positions.

The Make-Before-Break (MBB) switches provide uninterrupted power during switching.

MAKE-BEFORE-BREAK FEATURES

- Improves system reliability by eliminating momentary interruptions during switching operations typically associated with Break-Before-Make (BBM) sectionalizing switches.
- Replaces 2 or 3 two position loadbreak switches depending on application (Choose V-blade or T-blade type).
- Simplifies operational procedures.

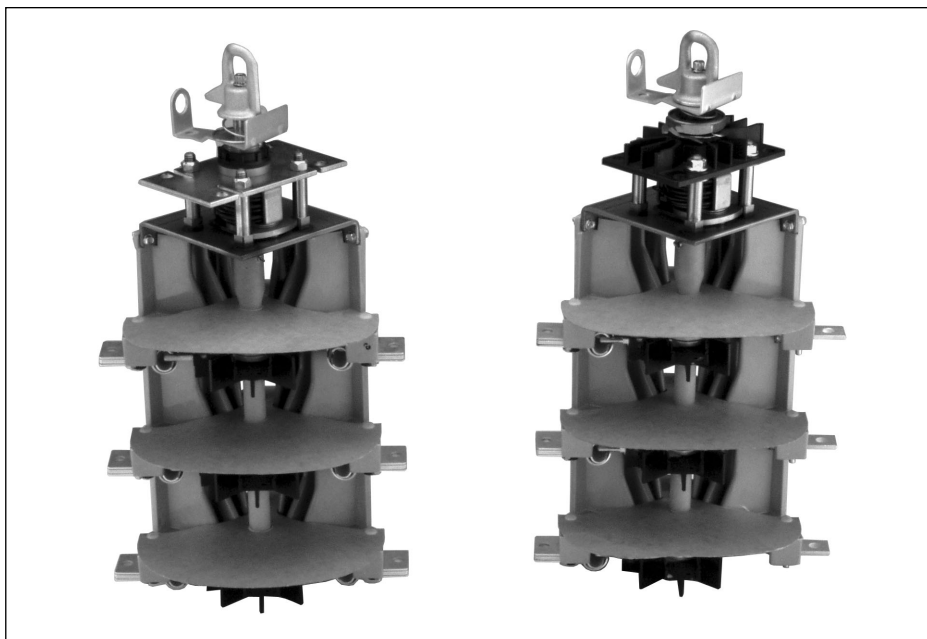

Figure 1. Sectionalizing Switches. Three-phase Bolt-In (left) and three-phase Quick-Mount (right).

- Make-Before-Break design available in both V- and T-blade switch types.

ATTRIBUTES

- Available for both 12 kA and 16 kA applications.
- Ratings from 200 A to 630 A and from 15 kV to 38 kV.
- Tested in mineral oil, R-Temp and Envirotemp FR3 fluids.
- All electrical switching tests performed at third-party certified test laboratories
- 5000 mechanical operations (meets IEC class M2 switch).
- All silver plated copper current path.
- Similar “footprint” as previous 10 kA switches (See Tables 3 and 4).
- The Quick-Mount System option offers easier and faster installation.
- Special vertical mounted switches available for cover mounted applications.

PRODUCTION TESTS

Tests are conducted in accordance with Cooper Power Systems requirements:

- Physical Inspection
- Mechanical operations
- Operating torque
- Contact pressure
- Switch contact resistance

INSTALLATION

The switch is either horizontally or vertically mounted, depending on the application and the selected switch type. The vertically mounted switch is typically used in transformers/switchgear installed below grade, where the switch would be mounted in the cover of that particular equipment. All exposed parts of the vertically mounted switch are made from stainless steel or other non-corrosive materials. Both types of switches, including the mechanism, must be completely immersed under the insulating fluid.

NOTE: For all mounting systems, refer to S800-64-2 for more detailed installation instructions.

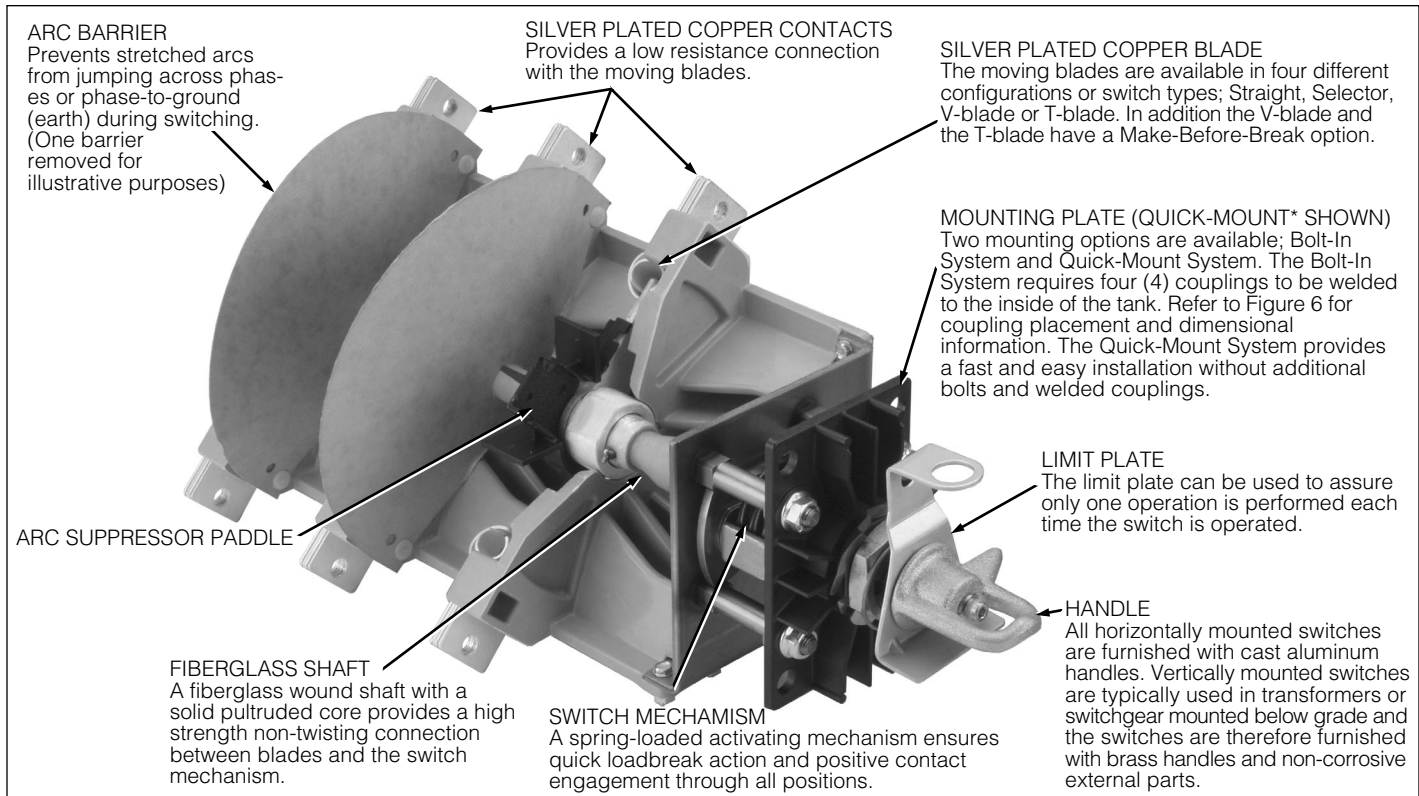

Figure 2.
Switch features and description.

* DuPont Zytel® HTN (High Temperature Nylon)

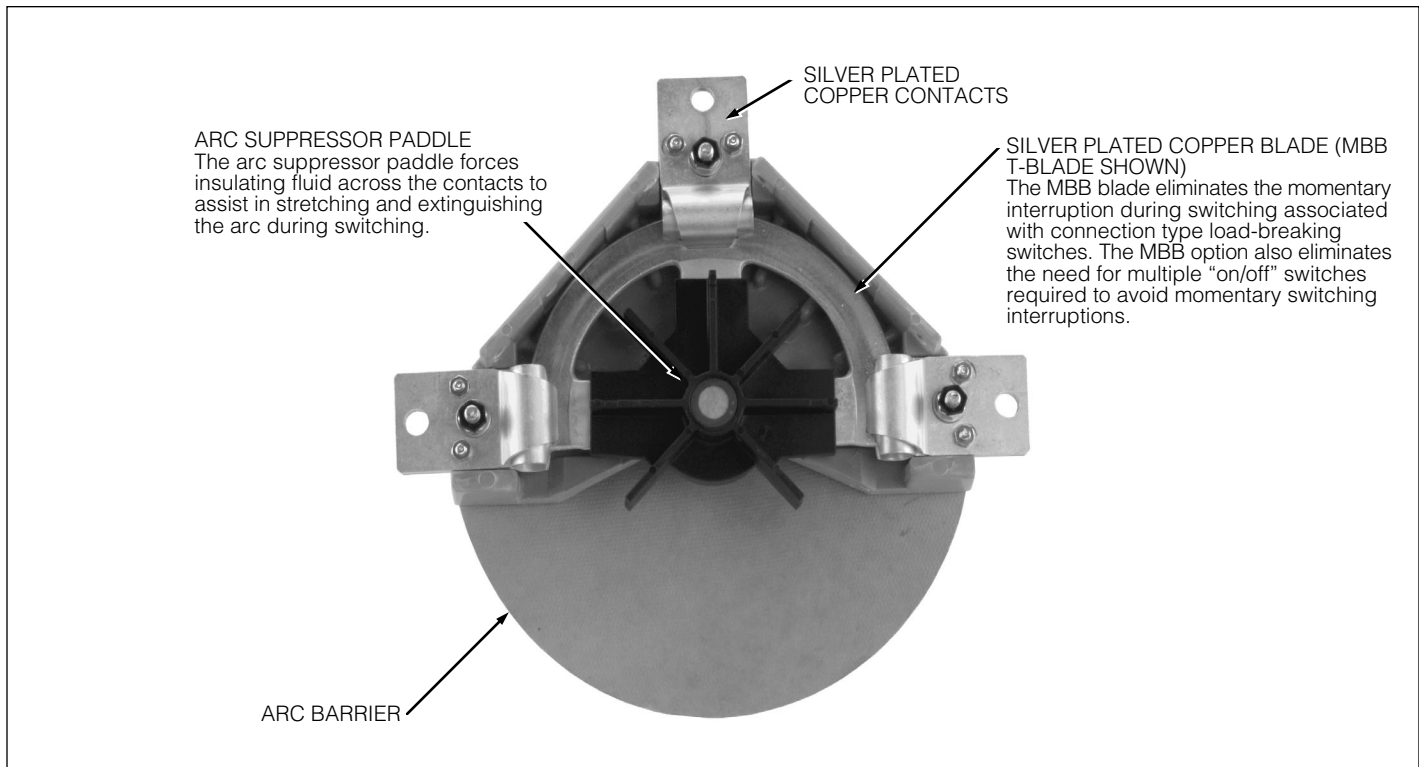

Figure 3.
Make-Before-Break switch features and description (See Table 5 for application details).

ELECTRICAL RATINGS

TABLE 1
Ratings and Characteristics per IEEE C37.71 – 2001™

	Units	12.5 kA Rated Switches To IEEE C37.71 - 2001™		
Rated Voltage				
Maximum rating phase-to-phase	kV	15.5	27.8	38
Maximum rating phase-to-ground	kV	9	17.2	21.9
Power Frequency	Hz	60	60	60
Current rating (Continuous)	A	630	300	200
Loadbreak Capability @ 0.75				
Power Factor	A	630	300	200
First peak min.	kV	4	7.6	13
Time-to-peak max.	µs	180	290	424
Magnetizing	A	22	10.5	7
Cable Charging	A	10	25	40
Fault Withstand Current (Momentary)				
10 cycle symmetric rms	kA	12.5	12.5	12.5
10 cycle asymmetric rms	kA	18.6	18.6	18.6
10 cycle peak	kA	32.5	32.5	32.5
Fault Withstand (Short-time)				
1s rms	kA	12.5	12.5	12.5
2s rms	kA	12.5	12.5	12.5
Fault Close and Latch				
10 cycle symmetric rms	kA	12.5	12.5	12.5
10 cycle asymmetric rms	kA	18.6	18.6	18.6
10 cycle peak	kA	32.5	32.5	32.5
Impulse Withstand Voltage (1.2/50µs)				
To ground and between phases	kV	95	125	150
Across open contacts	kV	95	125	150
Power Frequency (1 minute)				
To ground and between phases	kV	35	60	70
Across open contacts	kV	35	60	70
DC Withstand (15 minutes)				
To ground and between phases	kV	53	78	103
Across open contacts	kV	53	78	103
Corona (Extinction)	kV	26	26	26
Temperature Maximum at 630 A	°C	75	75	75
Temp. Rise Above Ambient Air at 630 A (Max.)	°K	35	35	35
Mechanical Life (Minimum Operations):		5,000	5,000	5,000

TABLE 2
Ratings and Characteristics per IEC 60265-1 – 1998

	Units	16 kA Rated Switches To IEC 60265-1 - 1998		
Switch Rating	kV	15	24	36
Rated Voltage				
Maximum rating phase-to-phase	kV	15.5	24.9	38
Maximum rating phase-to-earth	kV	9	14.4	21.9
Power Frequency	Hz	50/60	50/60	50/60
No-Load Transformer Breaking Current	A	6.3	4	2
Current Rating (Continuous)	A	630	400	200
Mainly Active Load Breaking Current	A	630	400	200
First peak min.	kV	25.7	41	65.1
Time-to-peak max.	µs	72	88	108
Closed Loop Breaking Current	A	630	400	200
Line Charging Current	A	1	1.5	2
Cable Charging Current	A	10	17	25
Earth Fault Switching Current	A	1	10	8
Cable and Line Charging Under Earth Fault	A	17.5	17	26
Short-time Withstand Current				
1s rms	kA	18	18	18
2s rms	kA	16	16	16
3s rms	kA	13	13	13
Short-circuit Making Current				
12 cycle symmetric rms (min.)	kA	16	16	16
12 cycle asymmetric rms (min.)	kA	24.8	24.8	24.8
12 cycle max. peak (min.)	kA	41.6	41.6	41.6
Impulse Withstand Voltage (1.2/50µs)				
To earth and between phases	kV	170	170	170
Across open contacts (isolating distance)	kV	195	195	195
Power Frequency (1 Minute)				
To earth and between phases	kV	70	70	70
Across open contacts (isolating distance)	kV	80	80	80
Corona (Extinction)	kV	26	26	26
Temperature Maximum at 630 A	°C	90	90	90
Temp. Rise Above Ambient Air at 630 A (Max.)	°K	50	50	50
Mechanical Life (Minimum Operations):		5,000	5,000	5,000

DIMENSIONAL INFORMATION

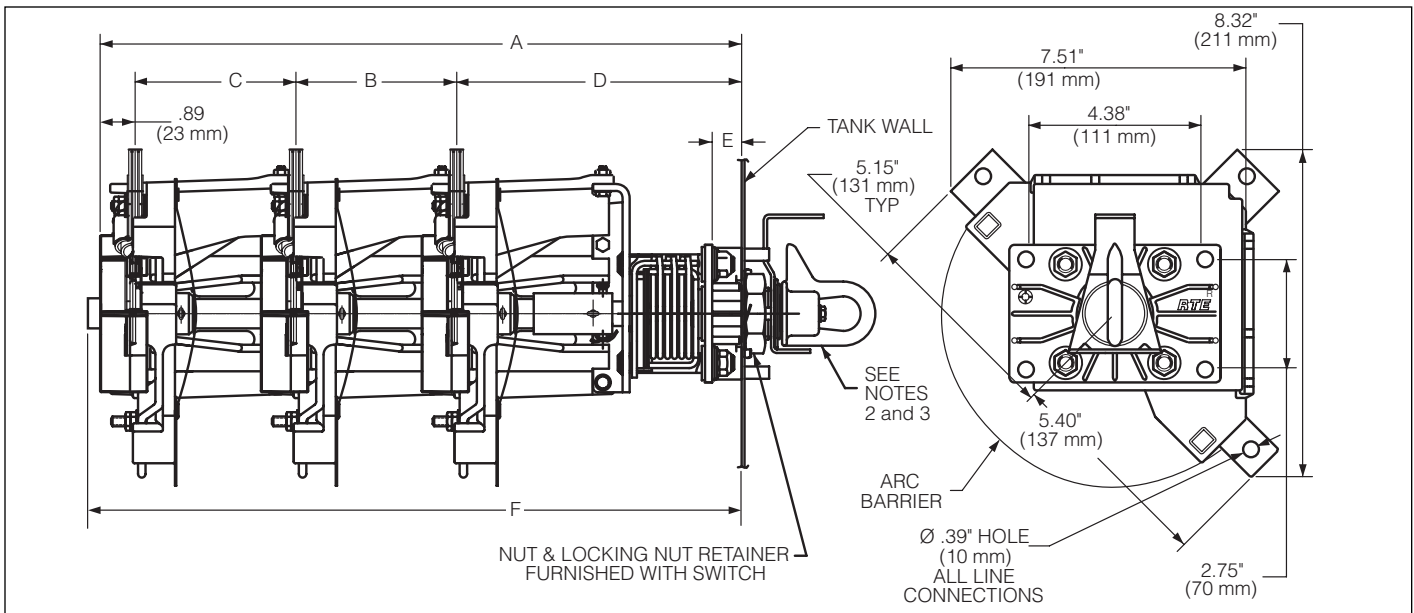

Figure 4.
Line illustration with dimensions of sectionalizing switch with “Quick-Mount System.”

Notes:

1. Dimensions given in Figure 4 and Table 3 are for reference only.
2. Handle can be used on 14 gauge .075 inch (1.9 mm) to .25 inch (6.4 mm) thick frontplate. 14 gauge shown.
3. Optional padlock handle is available. (See Table 7, Figure 7.)

TABLE 3
Dimensional Information for Figure 4 (Inches/mm)

No. of Decks/ Phases	kV Rating & Blade Type	A	B	C	D	E	F
		Horizontal Mount			Horizontal Mount		
1	All	8.14" 207 mm	–	–	7.25" 184 mm	0.75" 19 mm	8.54" 217 mm
2	All	12.23" 311 mm	4.09" 104 mm	–	7.25" 184 mm	0.75" 19 mm	12.54" 319 mm
3	12 kA T Blade 12 & 16 kA Selector, Straight, & V Blade	16.3" 414 mm	4.09" 104 mm	4.09" 104 mm	7.25" 184 mm	0.75" 19 mm	16.54" 420 mm
3	16 kA T Blade Only	16.7" 424 mm	4.09" 104 mm	4.09" 104 mm	7.65" 194 mm	0.75" 19 mm	16.94" 430 mm

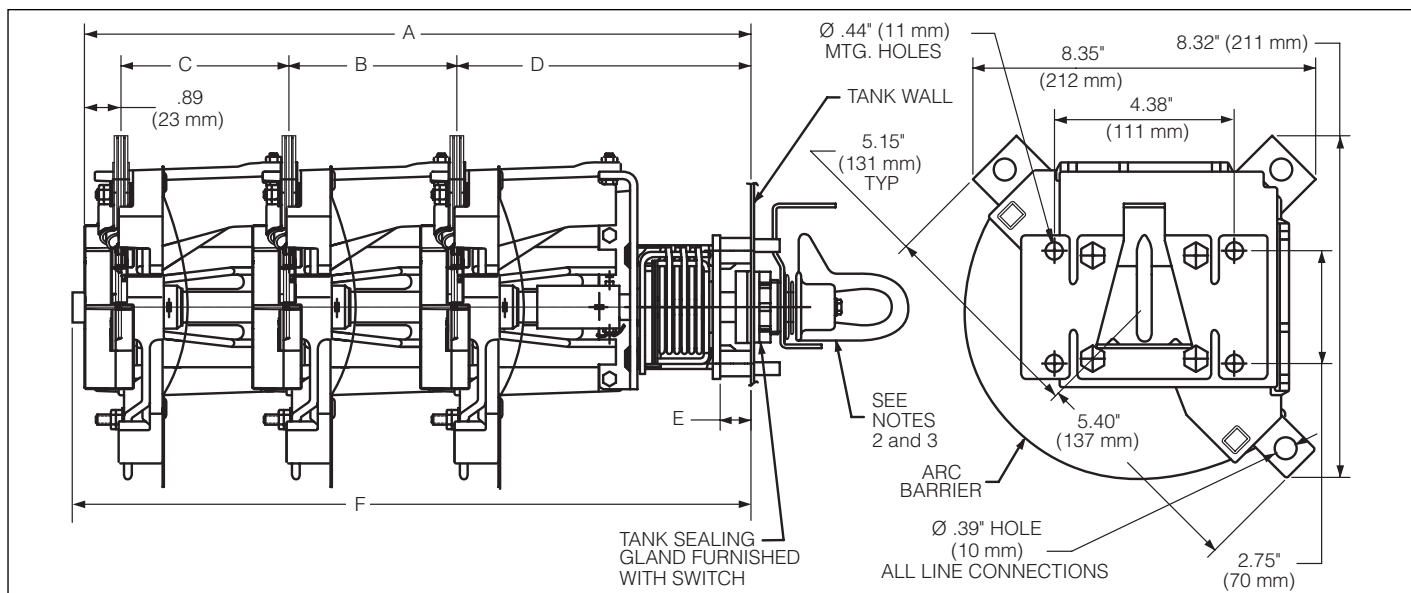

Figure 5.
Line illustration with dimensions of sectionalizing switch with “Bolt-In System.”

Notes: 1. Dimensions given in Figure 5 and Table 4 are for reference only.
 2. Handle can be used on 14 gauge .075 inch (1.9 mm) to .25 inch (6.4 mm) thick frontplate. 14 gauge shown.
 3. Optional padlock handle is available. (See Table 7, Figure 7.)

TABLE 4
Dimensional Information for Figure 5 (inches/mm)

No. of Phases/	kV Ratings & Blade Type	A		B	C	D		E		F	
		Horizontal Mount	Vertical Mount			Horizontal Mount	Vertical Mount	Horizontal Mount	Vertical Mount	Horizontal Mount	Vertical Mount
1	All	8.05" 204 mm	13.3" 338 mm	-	-	7.16" 182 mm	12.4" 315 mm	0.75" 19 mm	6.00" 152 mm	8.46" 215 mm	13.7" 348 mm
2	All	12.1" 307 mm	17.4" 442 mm	4.09" 104	-	7.16" 182 mm	12.4" 315 mm	0.75" 19 mm	6.00" 152 mm	12.5" 318 mm	17.7" 450 mm
3	12 kA T Blade 12 & 16 kA Selector, Straight, & V Blade	16.2" 411 mm	21.5" 546 mm	4.09" 104 mm	4.09" 104 mm	7.16" 182 mm	12.4" 315 mm	0.75" 19 mm	6.00" 152 mm	16.5" 419 mm	21.7" 551 mm
3	16 kA T Blade Only	16.7" 424 mm	-	4.09" 104 mm	4.09" 104 mm	7.56" 192 mm	-	0.75" 19 mm	-	16.9" 429 mm	-

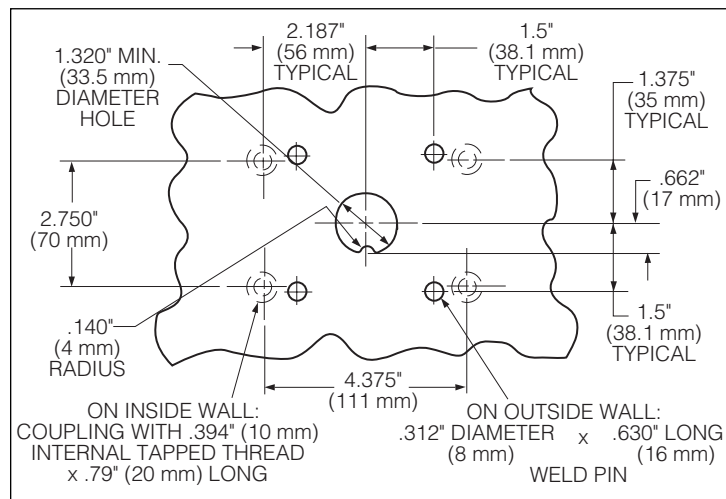

Figure 6a.
Hole, coupling and weld pin placement (Bolt-in system).

Notes:
 Couplings & Weld pins not included with switch. **Pre-Welded conversion mounting brackets available.** (See Table 7)
 All couplings and pins to be welded flat within an angularity tolerance of ± one half degree.

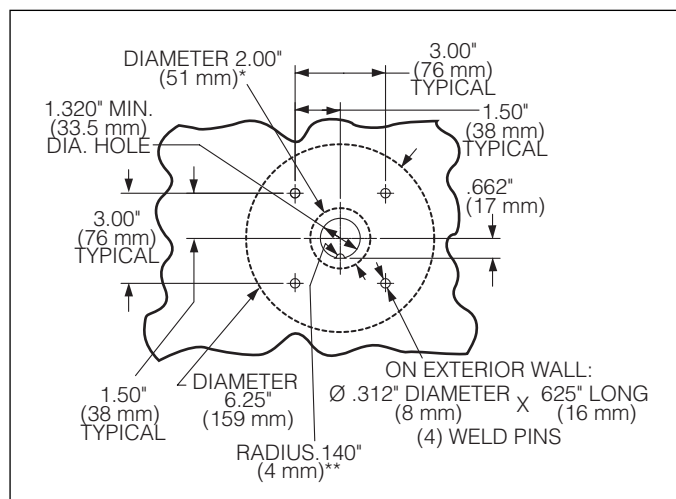

Figure 6b.
Hole and weld pin placement (Quick-Mount system).

* Exterior mounting surface must be flat within .010" (0.25 mm) over entire area.
 ** Interior mounting surface must be clear of obstructions.

TABLE 5
Wiring Schematics

SWITCH TYPE	TYPICAL DECAL STENCIL LAYOUT	VIEW OF CONTACTS FROM FRONT (HANDLE) END OF SWITCH	POSITION 1 FRONT SCHEMATIC AS SHIPPED AND AS SHOWN AT LEFT	POSITION 2 SCHEMATIC SWITCH HANDLE ROTATED 90° CLOCKWISE FROM POSITION 1	POSITION 3 SCHEMATIC SWITCH HANDLE ROTATED 90° CLOCKWISE FROM POSITION 2	POSITION 4 SCHEMATIC SWITCH HANDLE ROTATED 90° CLOCKWISE FROM POSITION 3
STRAIGHT BLADE	CLOSE OPEN OPEN CLOSE					
SELECTOR BLADE ON-OFF	CLOSE OPEN OPEN OPEN					
SELECTOR BLADE 1 BLADE SIDE	LINE A TO C OPEN LINE B TO C OPEN					
SELECTOR BLADE 1 BLADE CENTER	LINE A TO C OPEN OPEN LINE B TO C					
V-BLADE BREAK BEFORE MAKE	LINES A & B TO C LINE A ONLY TO C LINE B ONLY TO C OPEN (ALL)					
V-BLADE MAKE BEFORE BREAK	LINES A & B TO C LINE A ONLY TO C LINE B ONLY TO C OPEN (ALL)					
T-BLADE BREAK BEFORE MAKE	LINES A & B TO C LINE A ONLY TO C LINE B ONLY TO C LINES A TO B C OPEN					
T-BLADE MAKE BEFORE BREAK	LINES A & B TO C LINE A ONLY TO C LINE B ONLY TO C LINES A TO B C OPEN					

NOTE:
1. SWITCH CENTER IS PIVOT POINT. BLACK SEGMENTS OF BLADE ROTATE.
WHITE OUTLINED SEGMENTS ARE STATIONARY.
2. OTHER POSITION SEQUENCES AVAILABLE – CONSULT FACTORY FOR DETAILS.

ORDERING INFORMATION

To order a Cooper Power Systems four position sectionalizing loadbreak switch, specify the switch type desired from Table 5 and then build the catalog number from Table 6.

TABLE 6
Catalog Number Selection Chart

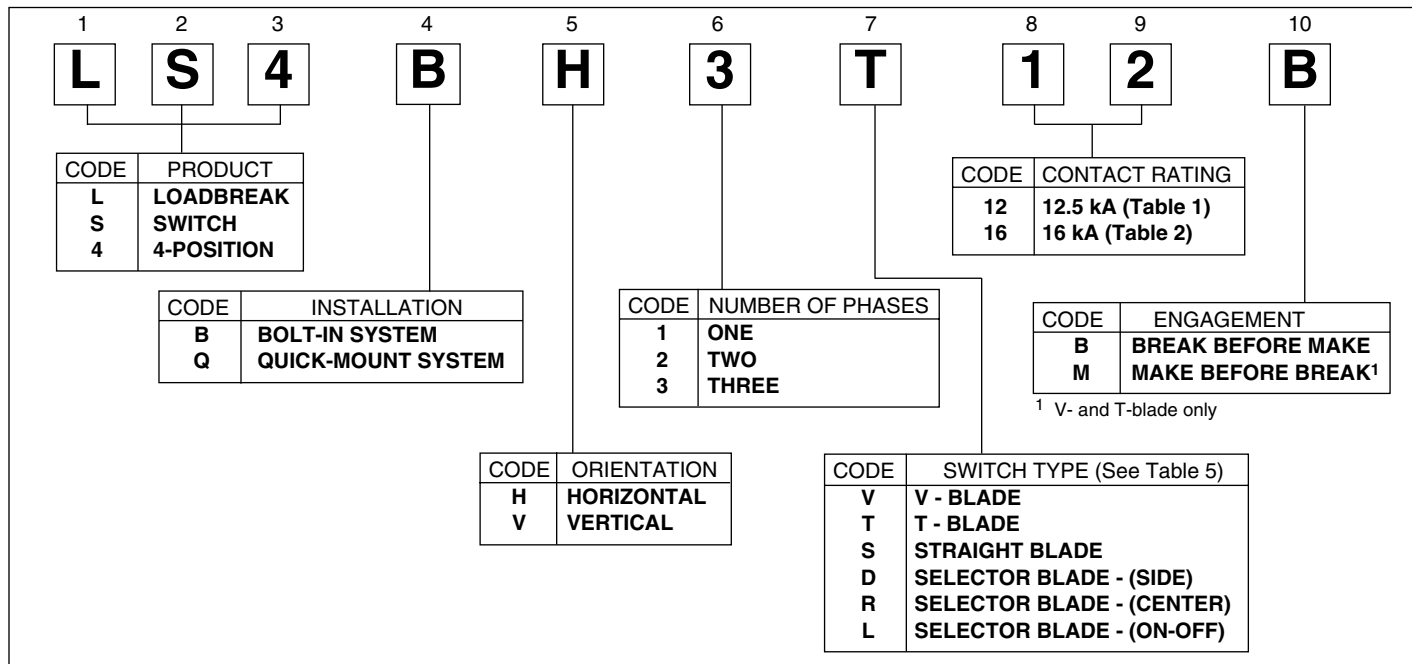

TABLE 7
Accessory Parts

Description	Catalog Number	Drawing
Conversion Mounting Bracket* for Bolt-In system. Includes hole, pins and couplings per Figure 6	2037424C02M	4200738N
Conversion Mounting Bracket* for Quick-Mount system. Includes hole and pins per Figure 6	2037424C04M	4200738N
Padlockable Handle** per Figure 7 Aluminum Brass	2239000B14 2239000B15	4201093N 4201093N

* Bracket is mild steel, 6" x 6" x 0.134" (152 mm x 152 mm x 3.4 mm).

** Padlockable handle must be ordered separately.

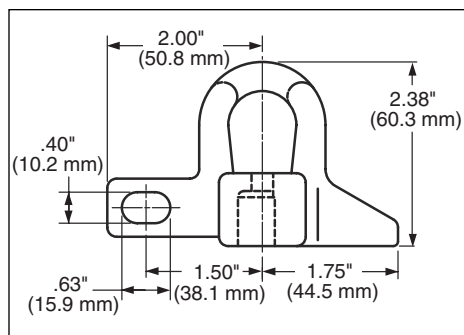

Figure 7.
Padlockable Handle.

Note: For use with interlock systems. Will not function with optional limit plate and weld pins.

ADDITIONAL INFORMATION

Refer to the following reference literature for application recommendations:

- Service Section:
Installation Instructions – S800-64-2
- Certified Test Report:
12 kA Four Position Sectionalizing Loadbreak Switch – CP0316
- Certified Test Report:
16kA Four Position Sectionalizing Loadbreak Switch – CP0313

© 2003 Cooper Industries, Inc.
R-Temp® and Envirotemp® are registered trademarks of Cooper Industries, Inc.
FR3™ is a trademark of Cooper Industries, Inc.
IEEE® is a registered trademark of the Institute of Electrical and Electronics Engineers, Inc.
IEEE Standard C37.71-2001™ is a trademark of the Institute of Electrical and Electronics Engineers, Inc.
Zytel® is a registered trademark of E. I. du Pont de Nemours and Company

The logo for Cooper Power Systems features a stylized black parallelogram above the word "COOPER" in a bold, sans-serif font, followed by "Power Systems" in a regular weight of the same font.

COOPER Power Systems

1045 Hickory Street
Pewaukee, WI 53072 USA
www.cooperpower.com